

Fracture Wall Tiles

Premier Collection

Fracture modular acoustic tiles are designed for versatile installation and design. Geometric patterns are beveled onto square and rectangular tiles to create spectacular full-scale patterns of rich color, depth, shadow, and texture.

Specifications

Surface	Wall
Material	FilaSorb™ polyester felt
Weight	12mm, 2400 gsm
Standard Sizes	300mm W x 300mm H 300mm W x 600mm H 600mm W x 300mm H



Fracture with Swell Pattern in Slate

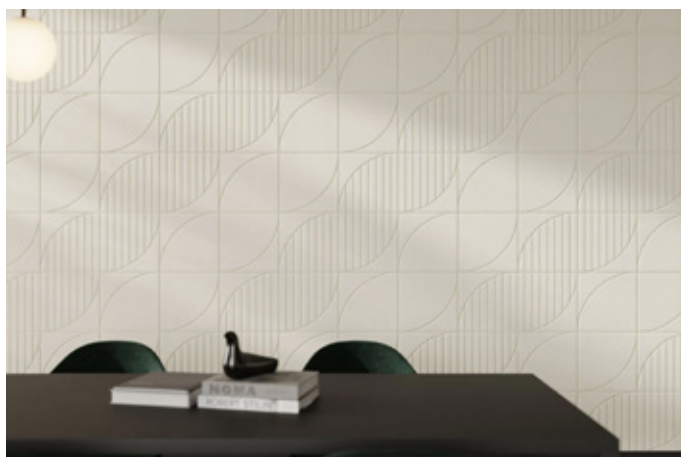

Fracture with Crescent 1-7 in White

Technical

NRC Rating	12mm* 0.45
Fire Test	Test Result Pending
Water Sorption	ASTM C1104-2019 (A Modified) Water sorbed by weight: 0.20% (based on a 12mm thick panel)
Colorfastness	ISO 105-B02, 6-7

* Test results available upon request.

Details

Lead Time	Refer to Product Lead Time Matrix
Origin	Australia
Warranty	Product: 20 years* Colorfastness: 20 years*

* Conditions apply

Environmental

Recycled Content	Minimum 60%
Energy	Generated using 40% solar energy
Indoor Air Quality	VOC less than/equal to 0.5mg/m3
Recyclable	100%*
Certifications	Health Product Declaration (HPD)** Environmental Product Declaration Declare Certification - LBC Red List Free (third-party verified) SCS Global Indoor Advantage Gold

* PET is recyclable through participating partners.

** HPD only applies to 12mm thickness.



® The Health Product Declaration® logo is a registered trademark of HPD Collaborative.



For questions or additional product information,
visit acoufelt.com.au or call **1800 626 462**

Fracture Wall Panels | April 2026

							
White WH12	Milkyway MI74	Ivory IV11	Pearl PE21	Valentine VA70	Quartz QU67	Stonewash ST72	Sea Salt SE57
							
Platinum PL04	Almond AL55	Pistachio PI25	Turmeric TU60	Flamingo FL61	Amethyst AM69	Periwinkle PE23	Peacock PE20
							
Metal ME03	Mushroom MU75	Celery CE65	Wheat WH68	Peach PE19	Lilac LI13	Marine MA15	Sencha SE58
							
Grey GR02	Umber UM54	Wasabi WA29	Popcorn PO26	Currant CU59	Berry BE06	Azure AZ05	Oregano OR18
							
Charcoal CH01	Walnut WA56	Eucalyptus EU71	Carrot CA08	Loganberry LO77	Granite GR62	Denim DE09	Kale KA12
							
Piano Black PI24	Slate SL27	Nori NO76	Peppercorn PE22	Shiraz SH63	Flint FL64	Midnight MI16	



For questions or additional product information,
visit acoufelt.com.au or call 1800 626 462

Fracture Wall Panels | April 2026

Sizes

Standard Sizes 300mm W x 300mm H
300mm W x 600mm H
600mm W x 300mm H

Elevation

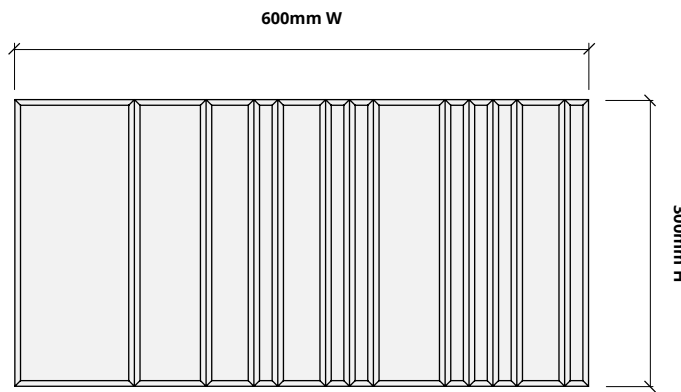

Patterns: Barcode 1, 2; Illusion

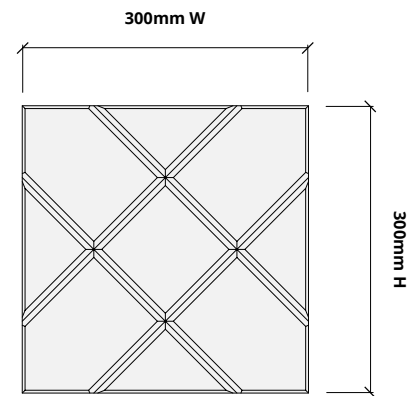

Patterns: Crescent 1-7, Crosshatch, Deco, Grid 1-5, Motif 1-5, Plaza

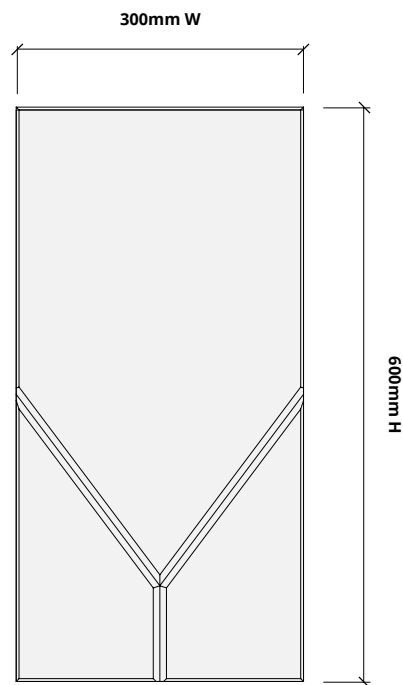

Patterns: Contrast 1, 2; Leadlight

How to Specify

1. Choose Thickness

2. Choose Tile Pattern

3. Choose Colorway

Determine preferred material thickness.

1. Choose Thickness

2. Choose Tile Pattern

3. Choose Colorway

Select desired panel pattern. See recommended layouts for larger designs.

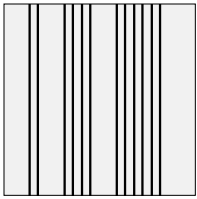

BARCODE 1,2

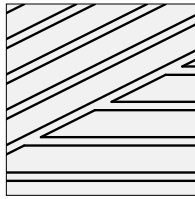

CONTRAST 1,2

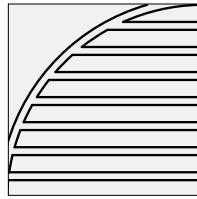

CRESCENT 1-7

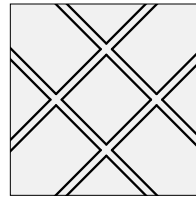

CROSSHATCH

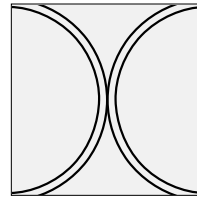

DECO

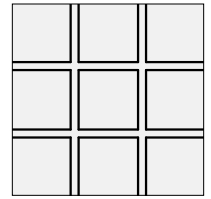

GRID 1-5

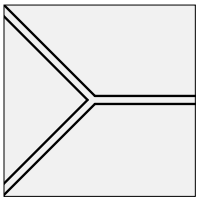

ILLUSION

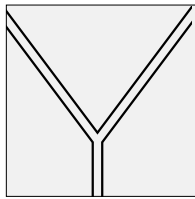

LEADLIGHT

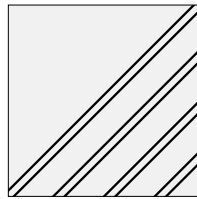

MOTIF 1-5

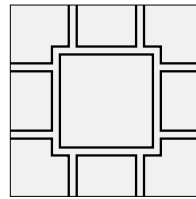

PLAZA

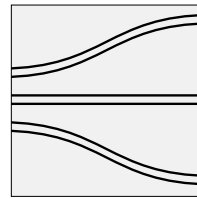

SWELL

1. Choose Thickness

2. Choose Tile Pattern

3. Choose Colorway

Select colorways on page 3.



For questions or additional product information,
visit [acoufelt.com.au](https://www.acoufelt.com.au) or call 1800 626 462

Fracture Wall Panels | April 2026

Recommended Layouts

BARCODE 1 (BA1)

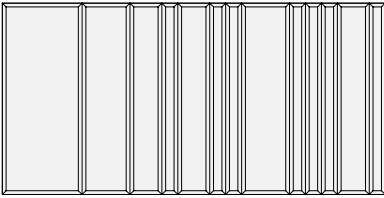

BARCODE 2 (BA2)

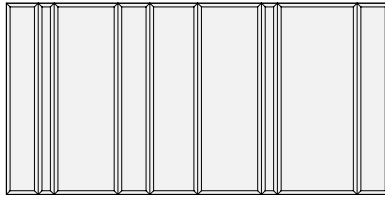

Layout 1 (100% BA1)

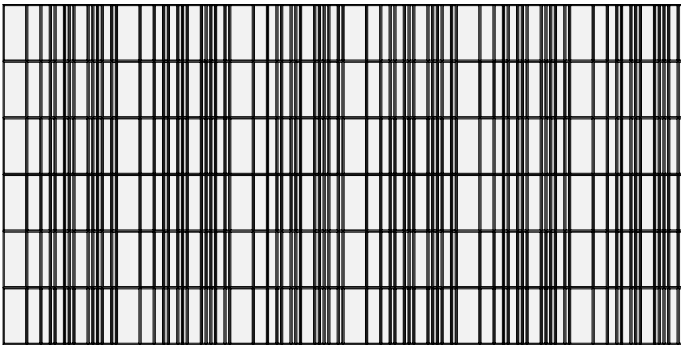

Layout 2 (100% BA2)

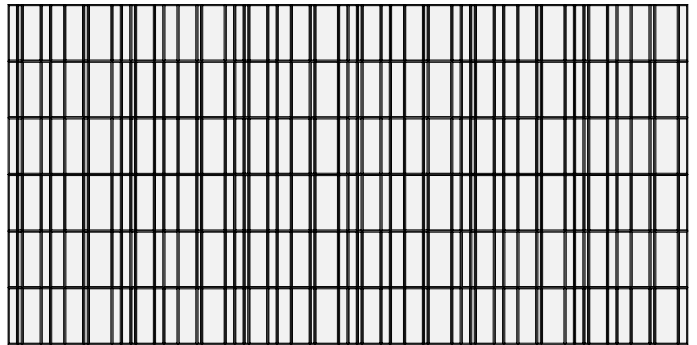

Layout 3 (50% BA1 & BA2)

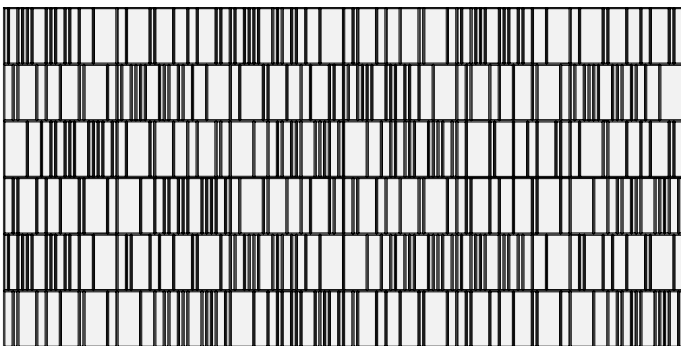

Recommended Layouts

CONTRAST 1 (CO1)

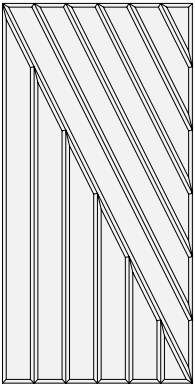

CONTRAST 2 (CO2)

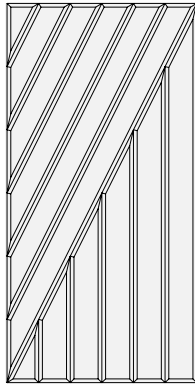

Layout 1 (100% CO1)

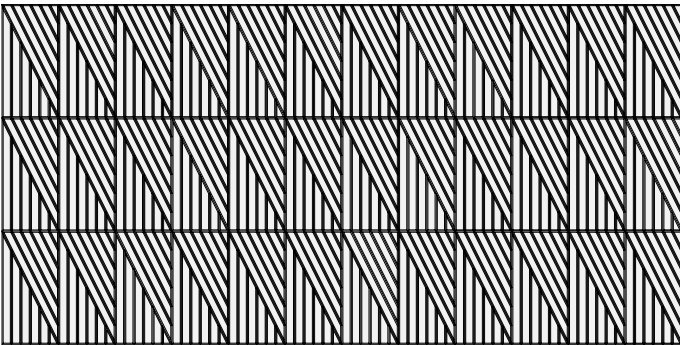

Layout 2 (100% CO2)

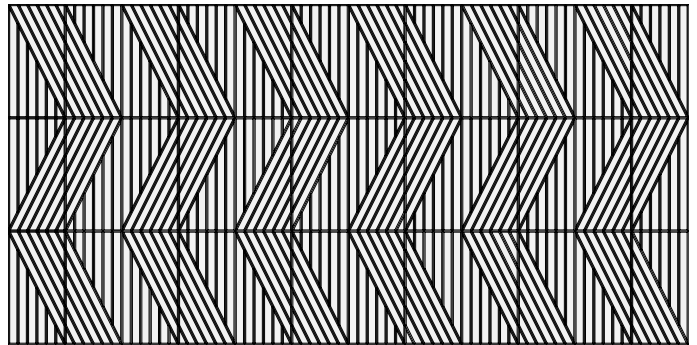

Layout 3 (50% CO1 & CO2)

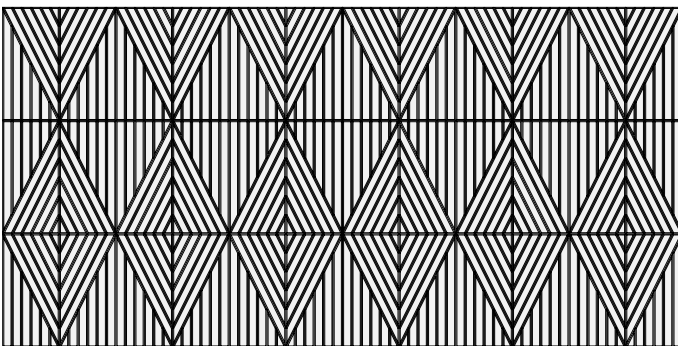

Recommended Layouts

CRESCENT 1 (CR1)

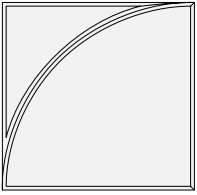

CRESCENT 2 (CR2)

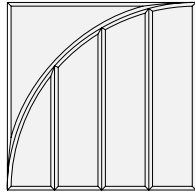

CRESCENT 3 (CR3)

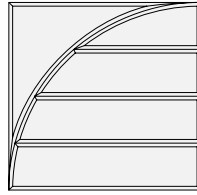

CRESCENT 4 (CR4)

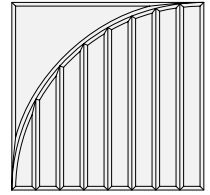

CRESCENT 5 (CR5)

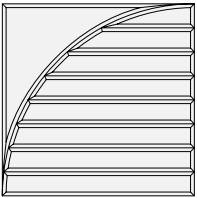

CRESCENT 6 (CR6)

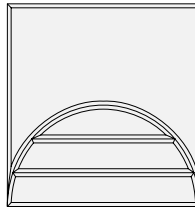

CRESCENT 7 (CR7)

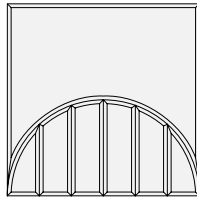

Layout 1 (100% CR3)

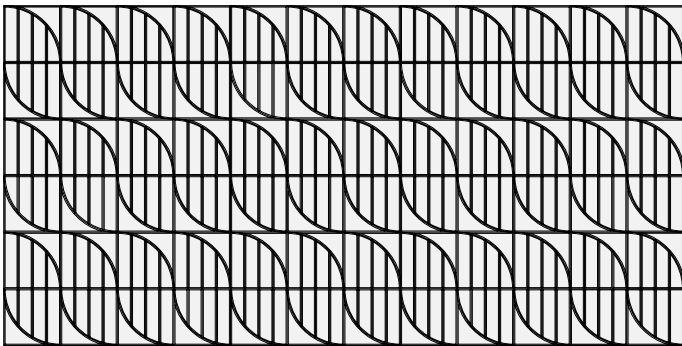

Layout 2 (50% CR1 & CR2)

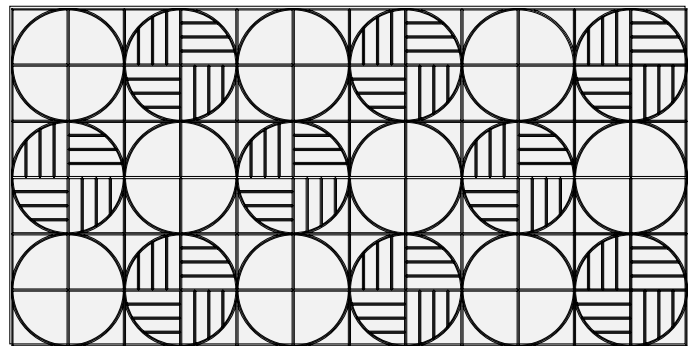

Recommended Layouts

Layout 3 (50% CR1 & CR4)

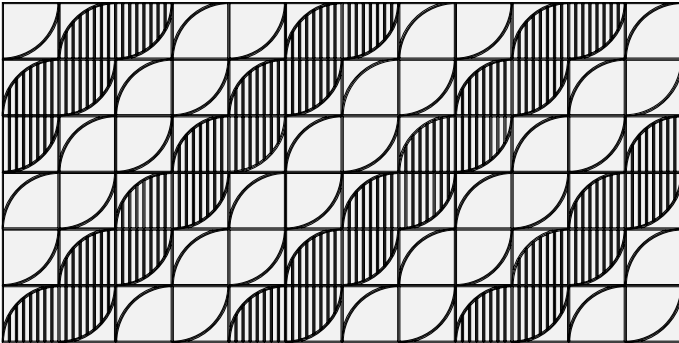

Layout 4 (50% CR6 & CR7)

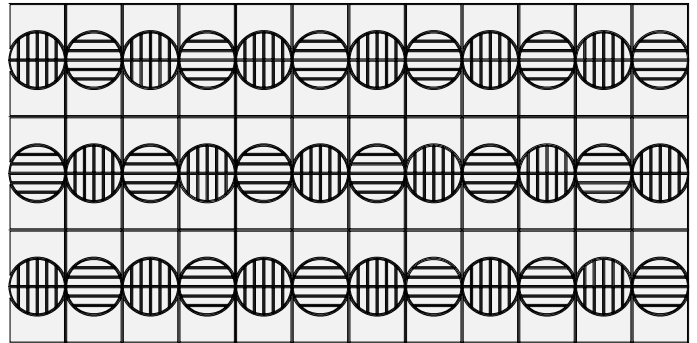

Layout 5 (16.5% CR1, CR4, CR6, CR7 & 34% CR3)

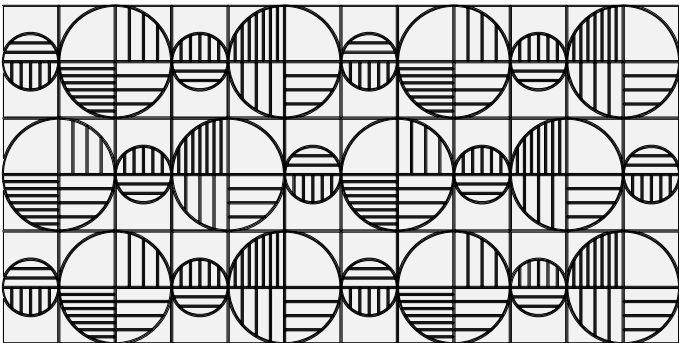

Layout 6 (24% CR1 & 12% CR2, CR3, CR4, CR5, & 14% MO1, MO2)*

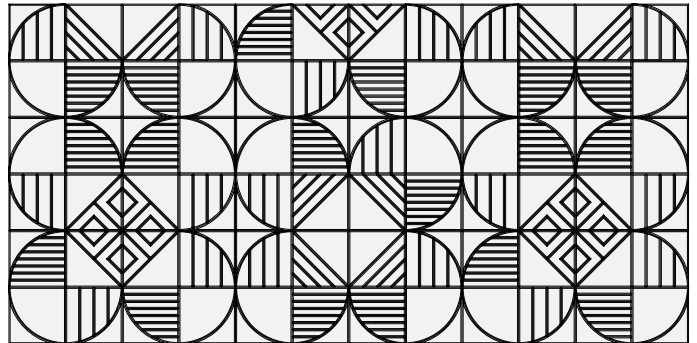

* Layout contains Motif family pattern.

Recommended Layouts

CROSSHATCH

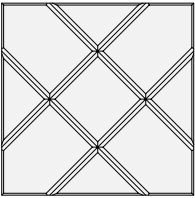

Layout 1

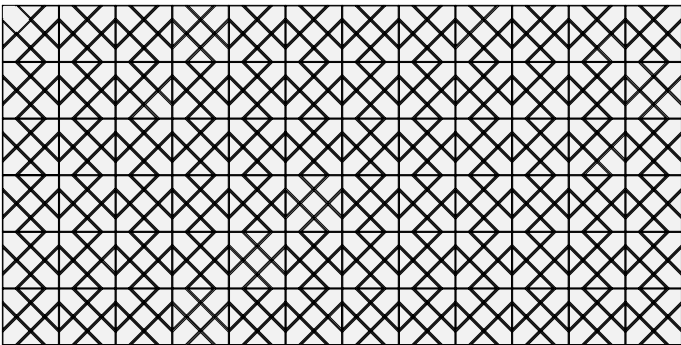

Layout

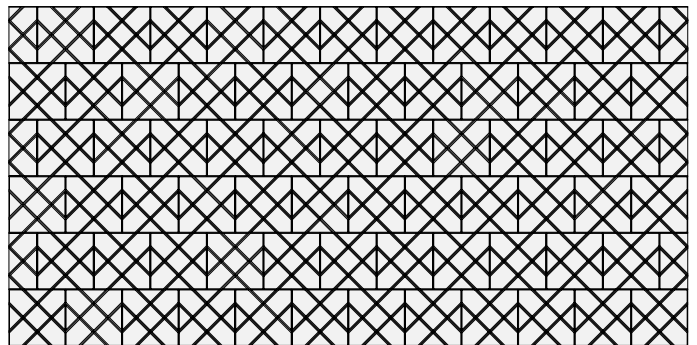

Recommended Layouts

DECO

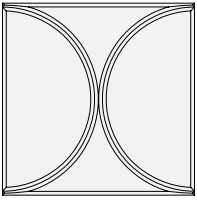

Layout 1

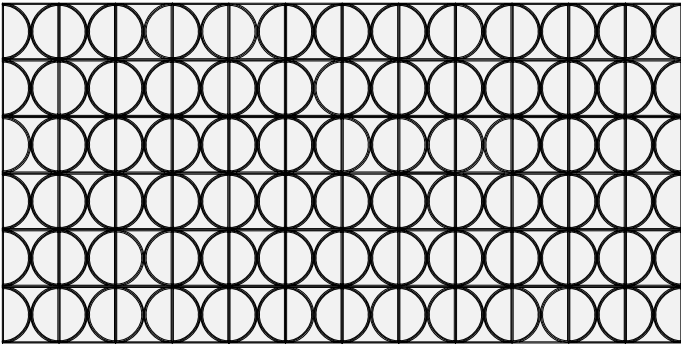

Layout 2

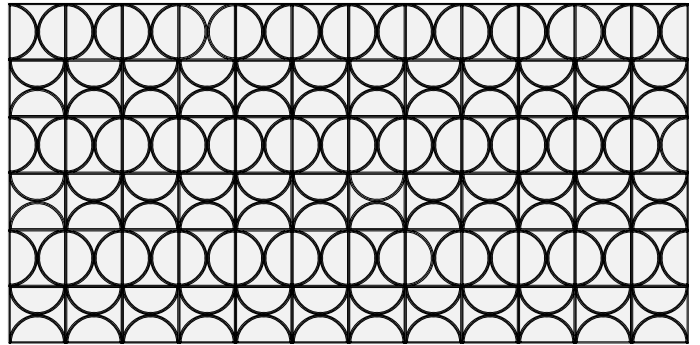

Layout 3

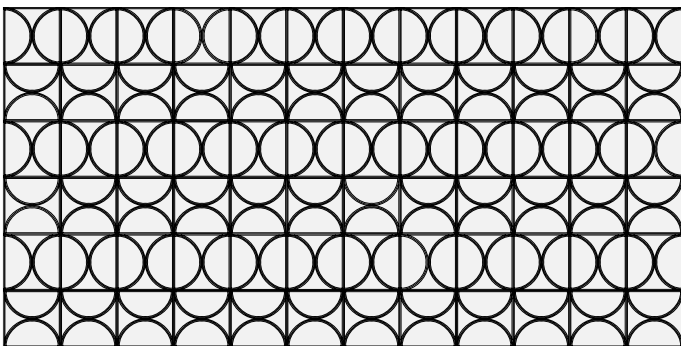

Recommended Layouts

GRID 1 (GR1)

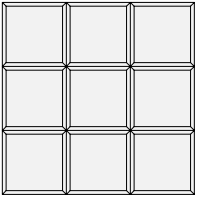

GRID 2 (GR2)

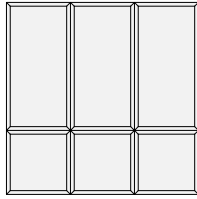

GRID 3 (GR3)

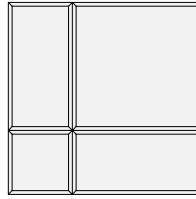

GRID 4 (GR4)

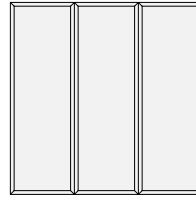

GRID 5 (GR5)

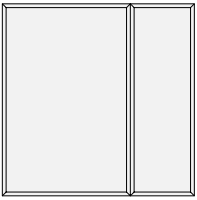

Layout 1 (100% GR1)

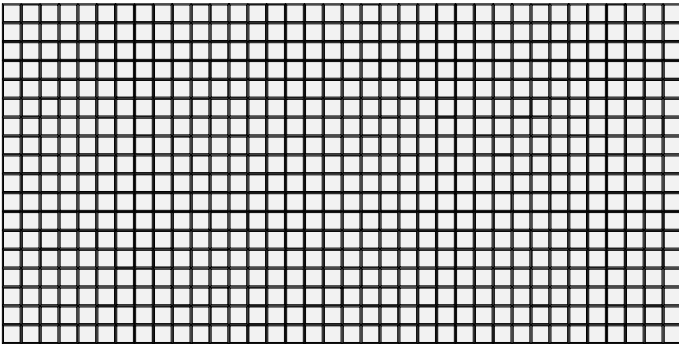

Layout 2 (100% GR2)

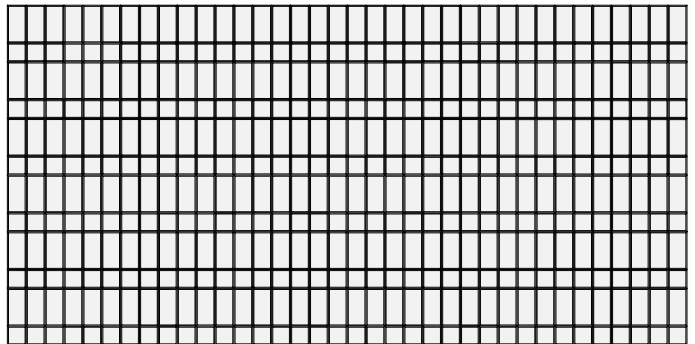

Recommended Layouts

Layout 3 (50% GR3 & GR5)

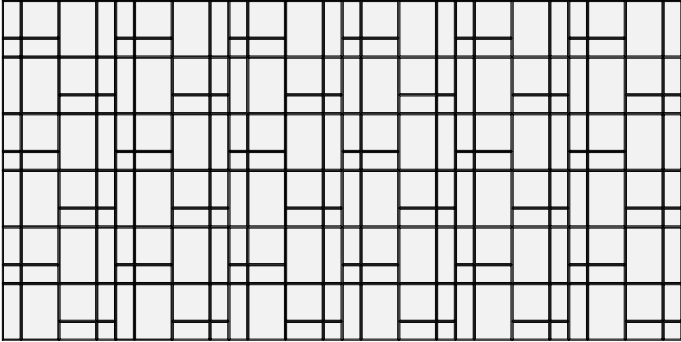

Layout 4 (33.3% GR2, GR3 & GR4)

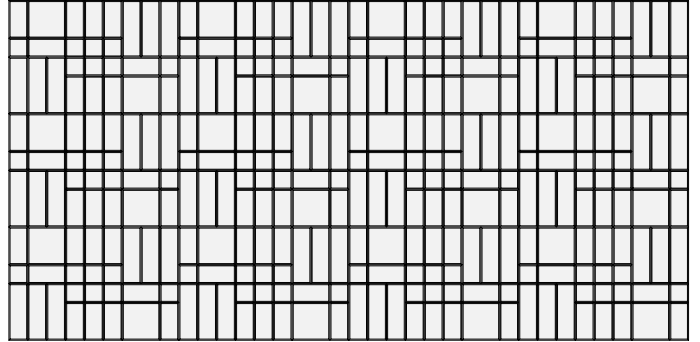

Layout 5 (25% GR1, GR2, GR4 & GR5)

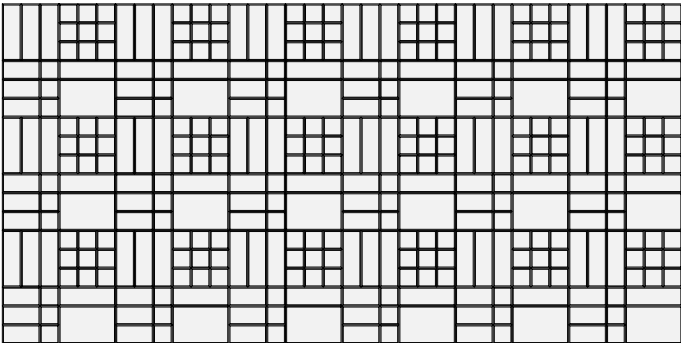

Layout 6 (20% GR1, GR2, GR3, GR4 & GR5)

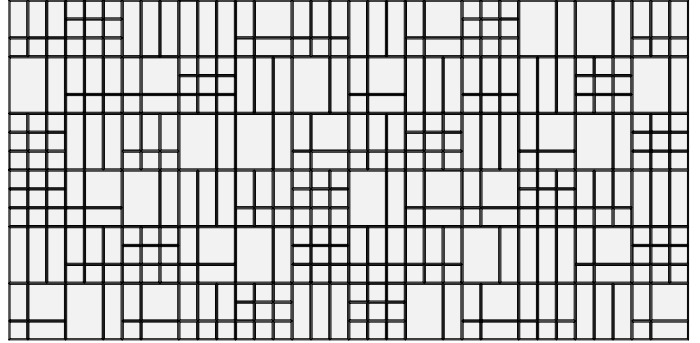

Recommended Layouts

ILLUSION

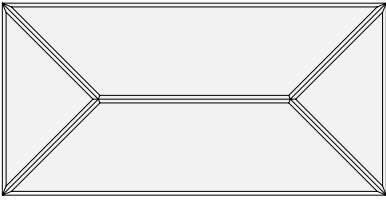

Layout 1

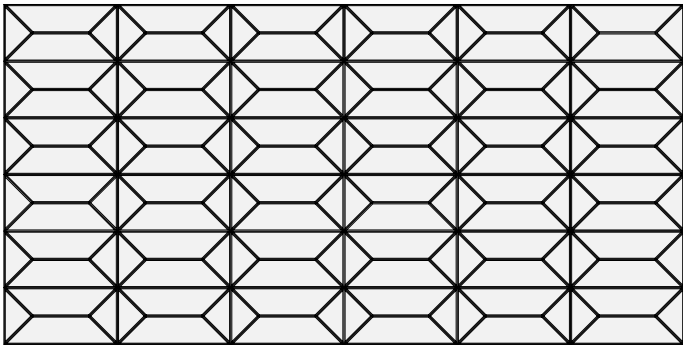

Layout 2

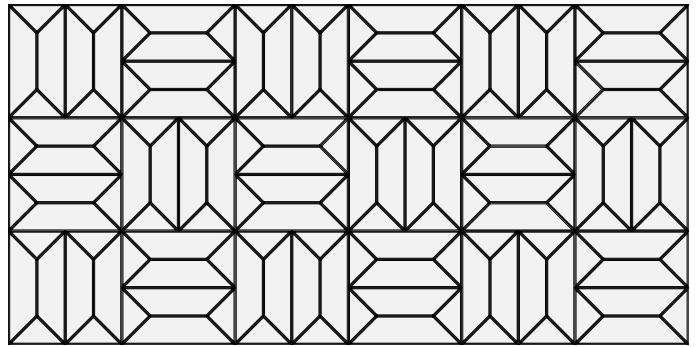

Layout 3

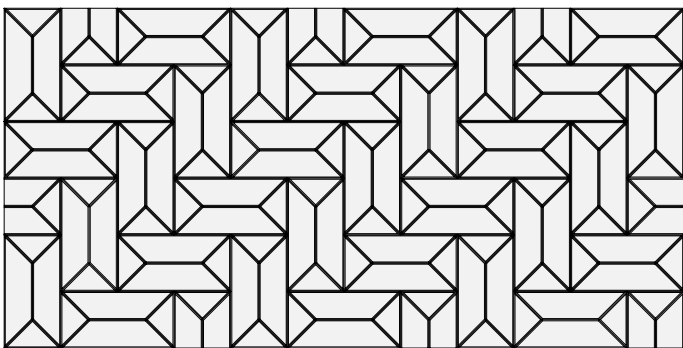

Recommended Layouts

LEADLIGHT

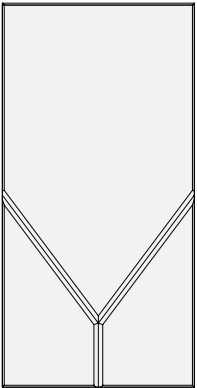

Layout 1

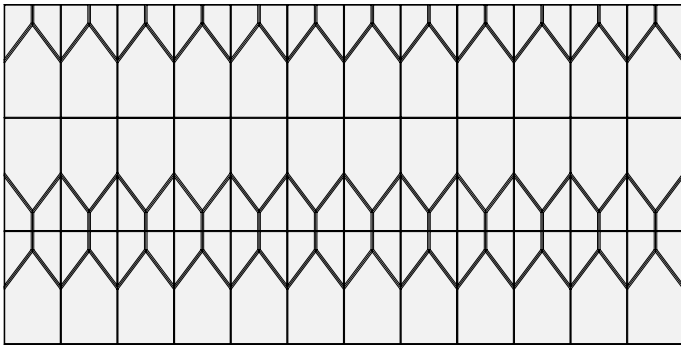

Layout 2

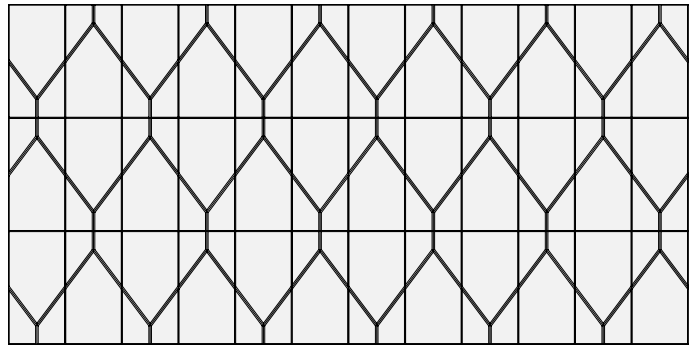

Layout 3

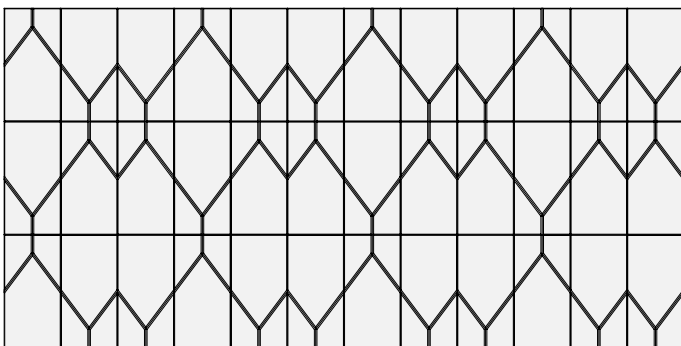

Recommended Layouts

MOTIF 1 (MO1)

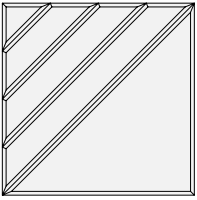

MOTIF 2 (MO2)

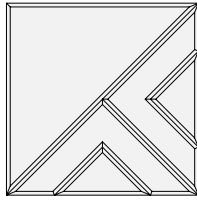

MOTIF 3 (MO3)

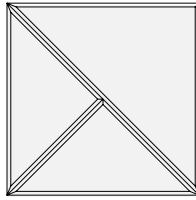

MOTIF 4 (MO4)

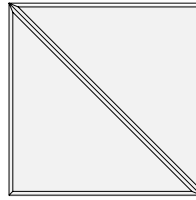

MOTIF 5 (MO5)

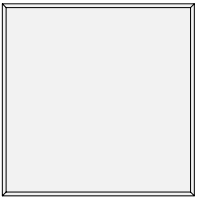

Layout 1 (100% MO1)

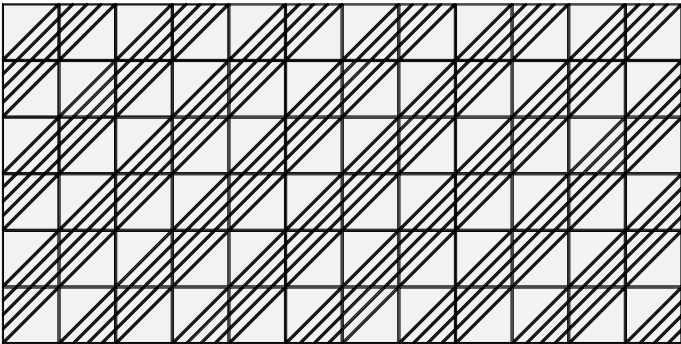

Layout 2 (50% MO3 & MO4)

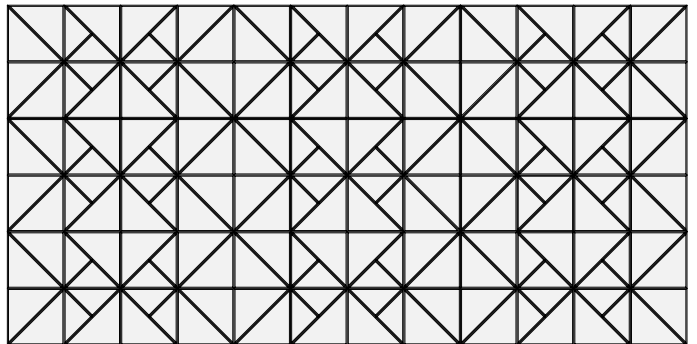

Recommended Layouts

Layout 3 (33.3% MO1, MO3, & MO4)

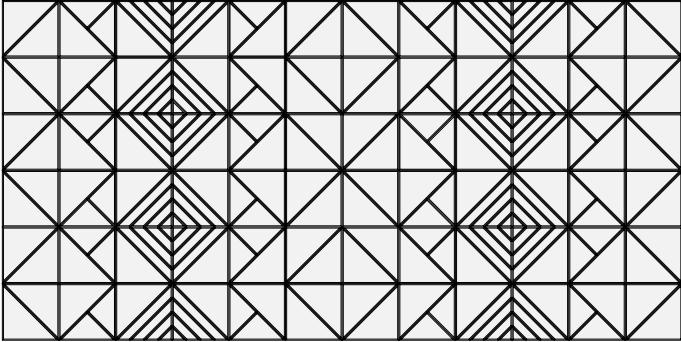

Layout 4 (25% MO1, MO2, MO3 & MO4)

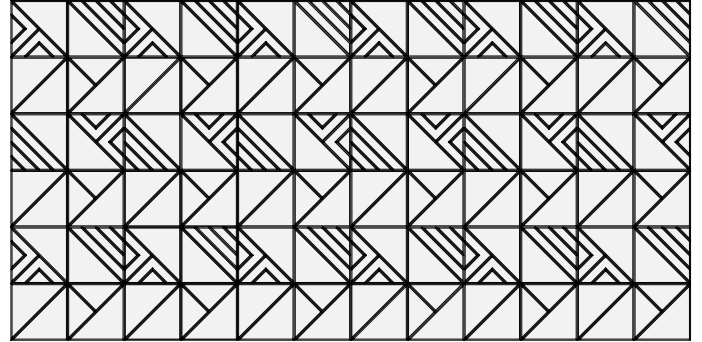

Layout 5 (24% MO1, MO2 & 18% MO3, MO4 & 16% MO5)

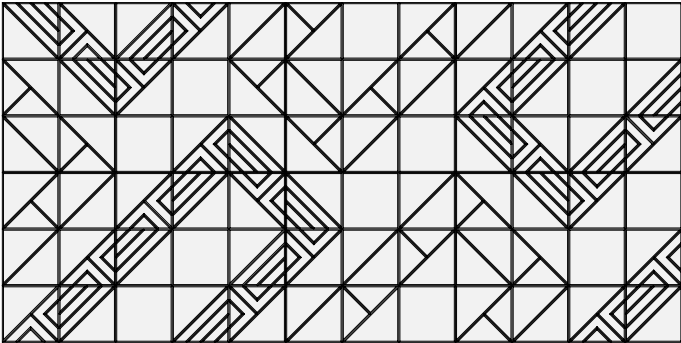

Layout 6 (4% MO1, MO2 & 24% CR1 & 12% CR2, CR3, CR4, CR5)*

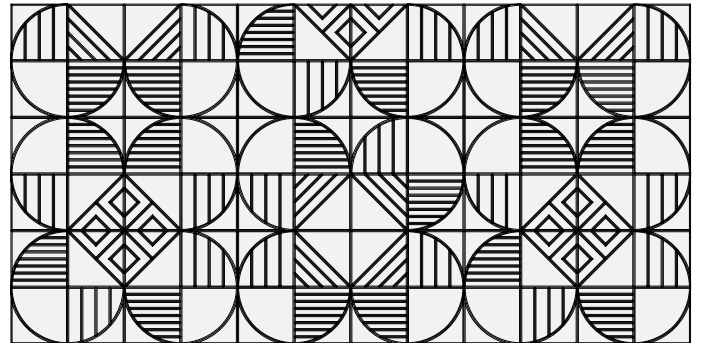

* Layout contains Crescent family pattern.

Recommended Layouts

PLAZA

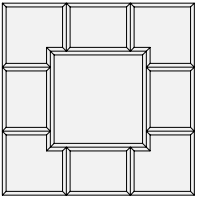

Layout 1

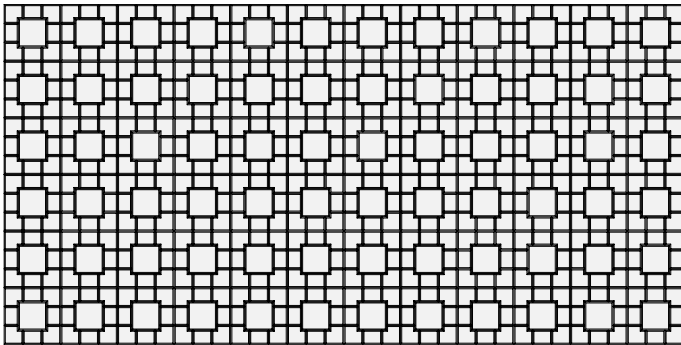

Layout 2

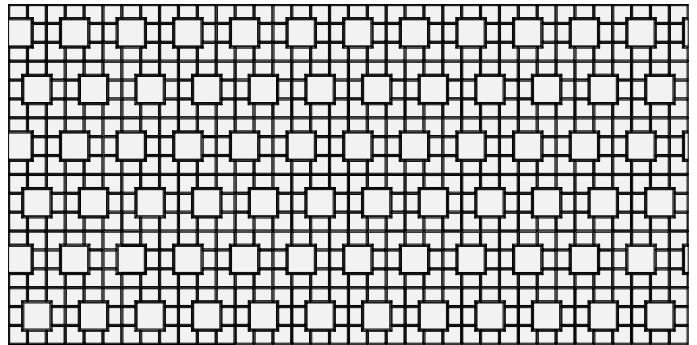

Mounting Methods

Adhesive backing

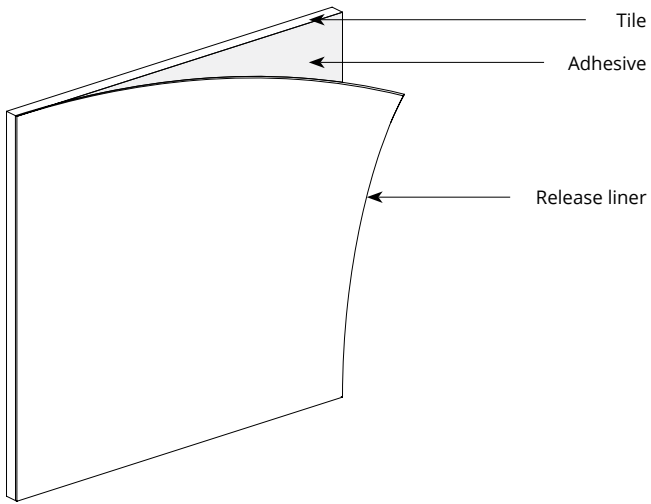

Construction adhesive

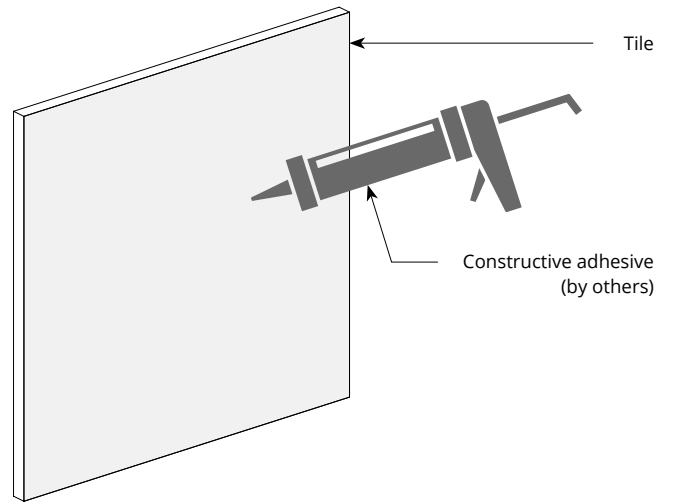

Acoustic Performance

Test Method	ISO 354-2006
Install Method	Type A
Mounting Method	No air gap
Rating Method	ISO 11654-1997
Test Results	12mm NRC 0.45 SAA 0.43

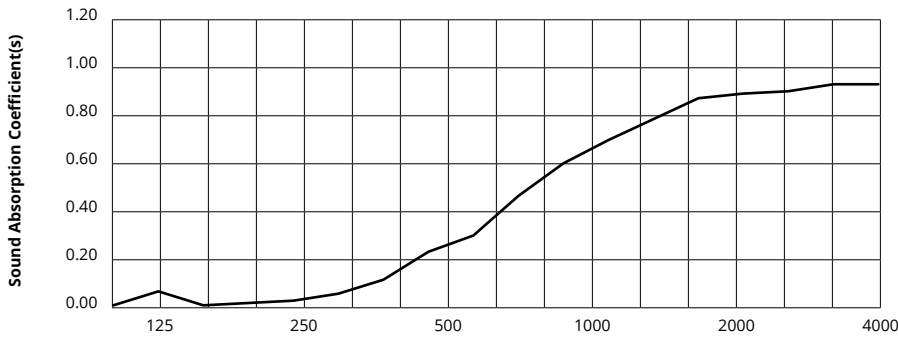

Frequency f (Hz)	125	250	500	1000	2000	4000	NRC
12mm	0.06	0.02	0.23	0.61	0.89	0.95	0.45

What is a Noise Reduction Coefficient (NRC)?

You'll find the NRC rating in the specifications of all of our products. This acronym stands for Noise Reduction Coefficient, and is expressed as a single number, a rating that describes the degree to which acoustic products can absorb sound.

You can use NRC values to understand the overall performance of our acoustic wall and ceiling products. The higher the NRC, the better the product is at soaking up the sound.

Performance Indices: Noise Reduction Coefficient (NRC) results represent the absorption coefficients measured at the one third octave bands at 125, 250, 500, 1000, 2000 and 4000 Hz rounded to the nearest 0.05. Acoustic testing has been performed according to the methods mentioned above. Customization of installation of the product could alter the results. Sound Absorption Average (SAA) indicates the absorption coefficient average for the twelve one-third octave bands ranging between 200 and 2500 Hz.

 For questions or additional product information, visit acoufelt.com.au or call **1800 626 462**

Fracture Wall Panels | April 2026